

Dual

1006

Service Manual

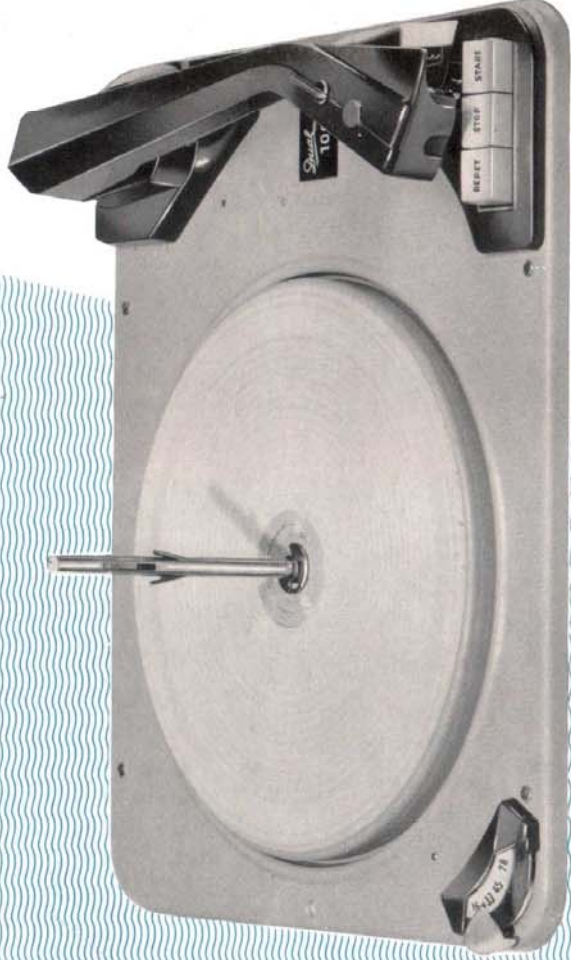

Record Changer 1006

· GEBRÜDER STEIDINGER · ST. GEORGEN / BLACK FOREST



Contents:

1. Technical Data
 2. Function of the individual parts
- Motor
- Turntable Drive
- Control of Tonearm
- Record Drop
- Automatic Shut-off
- End-of-Stack shut-off, "stop"-key (button)
- Start
- Manual operation
- Repeat switch
- Stereo-key
- Automatic lowering of Tonearm onto record
- Tracking pressure of Tonearm
3. Adjustments
 4. Schematic Diagram
 5. General Notes

1. Technical data

- Input Voltage: 110 / 220 V AC
- Frequency: 50 or 60 cps
- Power Consumption: app. 13 watts
- Drive: 4-pole induction motor with low external field
- Speeds: 78, 45, 33 and 16 rpm
- Tonearm: Will accept all cartridges having standard US mounting dimensions; also available with DUAL Wide Range Crystal Cartridge CDS 420 / 4
- Weight: 11.3 lbs (5.1kg)

2. Function of the individual parts

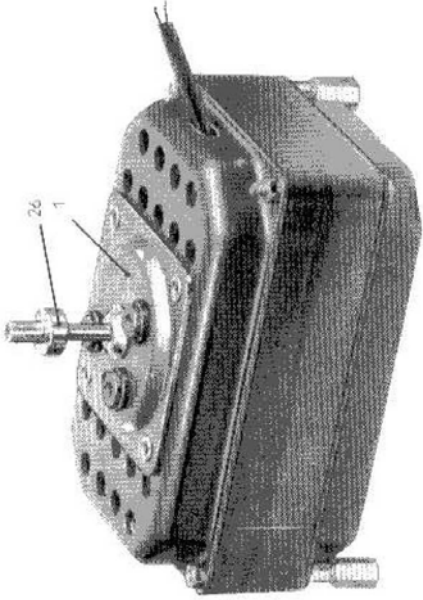

Motor

Both the turntable and the other drive components are driven by a 4-pole induction motor (1) having an extremely low external magnetic field and vibration-free operation.

The speed of the motor is constant within 10% of the nominal line voltage. Deviation is dependent upon and proportional to the line frequency. Matching the motor to a 50 or 60 cps line is accomplished by use of different motor pulleys (26). Motor pulleys for 50 or 60 cycles can be supplied by the factory. For the installation and removal of these motor pulleys, a special tool (pull-off Tool KDW 101) can be supplied by the factory. If changing the motor pulley becomes necessary great care must be exercised to prevent bending of the motor shaft. Failure to do this may cause rumble and flutter.

Motor

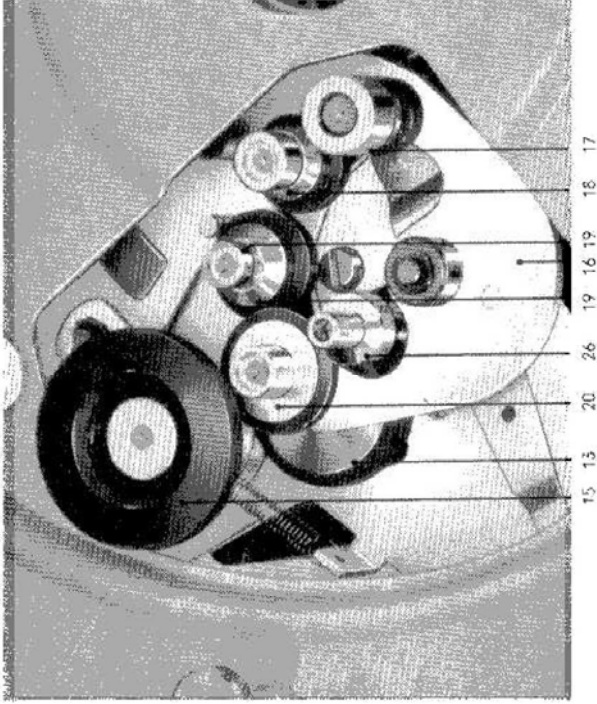

Friction Wheel Drive

Turntable Drive

Turntable speeds of 16, 33, 45, and 78 rpm are accomplished by the selection of the proper friction drive (16) which reduces the speed of the motor.

Drive of the turntable (87) is made by means of a drive wheel (idler) (15). To prevent damage to the rubber covering of the drive wheels the entire drive mechanism is automatically disengaged when the record changer is inoperative. A high degree of freedom from rumble is further achieved by grinding the rubber coverings concentrically with the wheel bearings. Keep lubricants away from all parts of the friction drive mechanism.

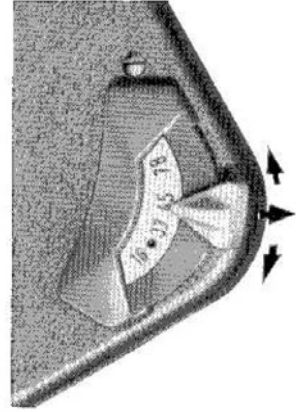

Speed Selector

For transportation purposes all intermediate drive wheels (17—20) should be disengaged. For this purpose a "neutral" position is provided on the speed selector switch.

Equal change cycle duration regardless of turntable speed is accomplished through the use of the cycle drive wheel (13) and its inward movement relative to the turning of the cam wheel (156). The intermediate wheels (17—20) are disconnected during this interval.

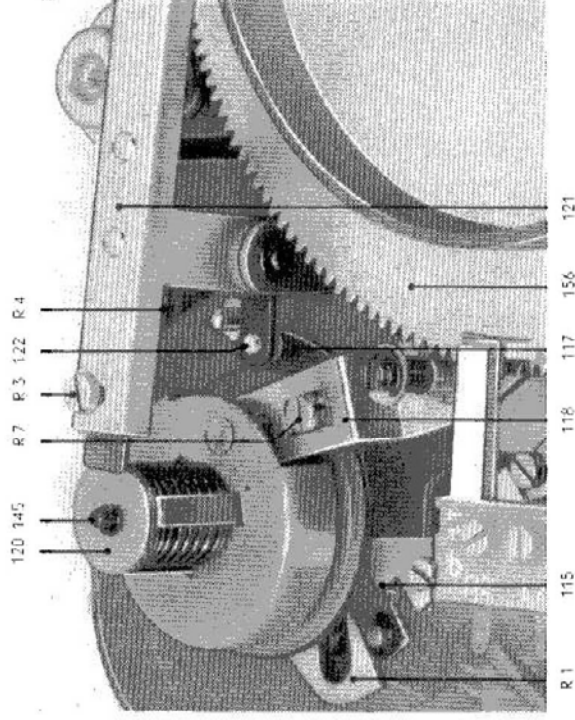

Mechanism for Tonearm Control

Control of Tonearm

The movements of the tonearm for lowering and raising are effected by cams on both sides of the cam wheel (156) when rotated through 360 degrees. The control elements consist mainly of the lifter (lift arm) and the lift rod (145) for the lifting action, and the cam lever (118) for horizontal movement of the arm.

Exception to the above is the movement of the arm, once it is dropped onto the record and the backward or outward movement to find the starting groove. These functions are accomplished by a slight angle on the position of the pick-up rollers.

Note:

For proper servicing be sure turntable is level.

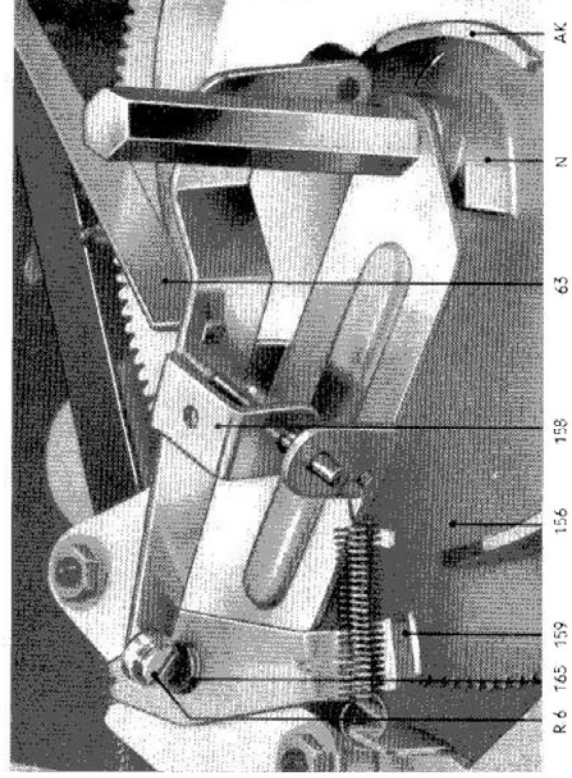

Mechanism for Record Drop

Record Drop

Two spindles are provided for stacking and dropping of records. For standard records (small center hole), changer spindle (172) is provided while for 45 rpm records a special drop spindle AS 6 (175) is available.

The dropping process is triggered (set off) by a revolution of the cam wheel (156) whose cam (AK) trips the ROCKER ARM (158) and the changer rod (165). The lift of the changer rod (165) then causes a record to drop either from the changer spindle or the 45-spindle.

The drop cam (AK) on the rim of the wheel (165) is so arranged that a record can only be dropped when the arm is in the right-hand position, that is beyond the outside diameter of a 12-inch record.

Shut-off

The start of the changing cycle after playing a record, and the final switch-off action after the last record of a stack has been played, are effected by the catch (dog) of the turntable pinion (87 a) and the shut-off pawl (124).

The shut-off pawl will move during the playing cycle, with the aid of the draw link (115) and will approach the catch on the turntable pinion.

Because of its angle, the shut-off pawl (124) will be held off by the catch (87 a) as long as the advance is only one groove wide.

Only the end-spiral with its greater feed causes the shut-off pawl to swing out and closer to the catch with each revolution. The pawl is now caught by the catch and pulled through. This movement is transmitted through the friction disk (125) to the cam wheel (156) which is taken out of its rest position and brought into mesh with the pinion of the turntable.

a) Final Shut-off

b) Stop-Key

a) After the last record has been dropped, the feeler bar (159) causes the lift rod (AB) to move vertically when the cam wheel is rotated. The lift rod touches the angle stop (114) and thereby alters the position of the cam follower (118) which is then switched over to the second part of the cam.

Through this operation the arm will move to its rest position, and thereby cause power shut-off as well as disengagement of the drive wheels.

b) The same effect, as mentioned under a) above is also caused by depressing the "STOP"-key (65). This causes the stop bar (56) to engage the angle stop (114) which in turn forces switching of the cam lever (118) and thereby provides shut-off of the mechanism.

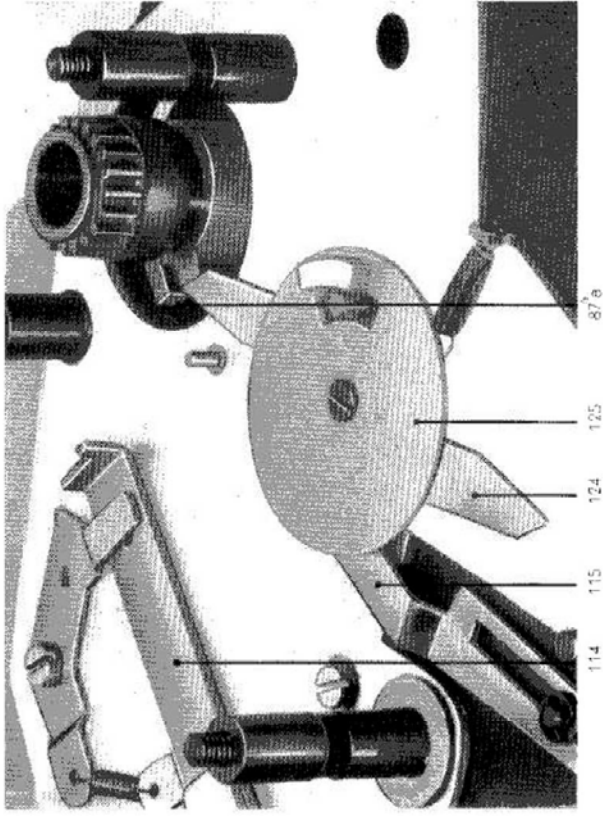

Shut-off Device
(cam wheel removed)

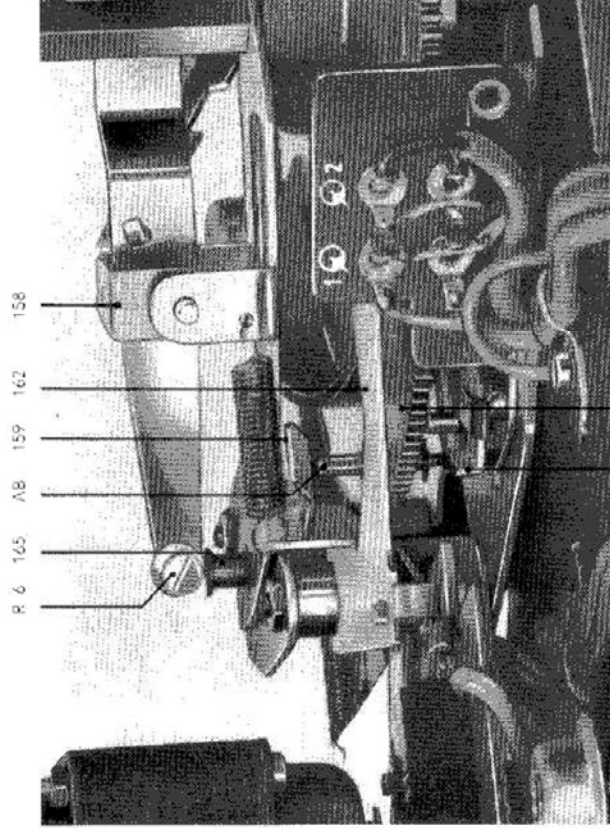

Functional Switch Mechanism

63 47 56 57a 62

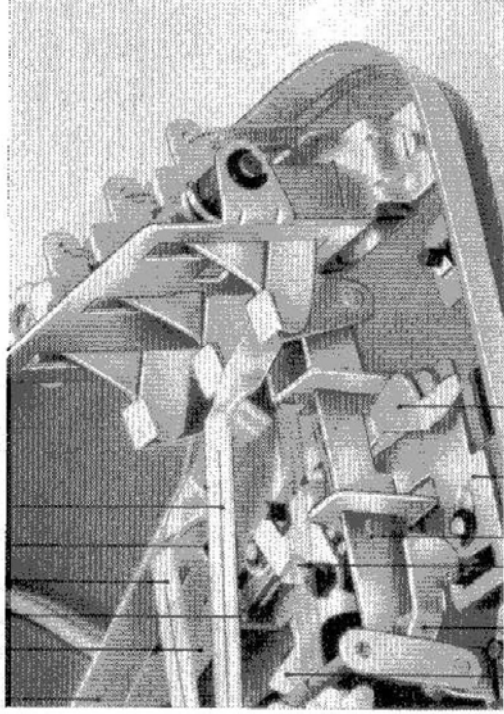

Push-Button Control with Power Switch

Start

Operation of the "Start"-key results in three simultaneous functions.

- a) Movement of the start bar (62), the start-link (116) and the start-angle (130) causes the cam wheel (156) to move out of its rest position and thereby mesh with the turntable pinion (87 a).
- b) The slider (48) changes the position of the cut-off lever (50) and operates power switch (53).
- c) The slider (48) moves the engagement lever (49), lift bar (47) and lifter (14) at the same time, thereby engagement of the idler wheel (15) and the turntable (87) take place.

All of the above functions result in proper record drop and automatic lowering of the arm.

Manual Operation

In this method of operation it is possible to move the arm to any desired spot on a record -- actuating the "Manual"-key (59) will then start the record without any delay.

A second method of manual operation of the arm consists of depressing the "Manual"-key (59) then moving the arm by hand onto the rotating record. (Note: Turntable will rotate only after arm has been lifted from its rest.)

Repeating

This operation can be achieved by pressing down the "REPET"-key (66) which causes the repeat bar (63) to move the dropping lever (158) out of reach of the cam (AK) which is part of the cam wheel (156). Return of the dropping lever (158) is done through the cam (N) located on the shaft of the wheel (156) after the tone arm engages the record and the cam (156) finishes its cycle.

Stereo-Key

The lever switch (K) is to be placed into the applicable position (OO for Stereo Records) or (O for monaural records). This device serves to control the stereo effect and to provide an improvement of monaural reproduction by placing the two channels in parallel when the switch is in the "O" position.

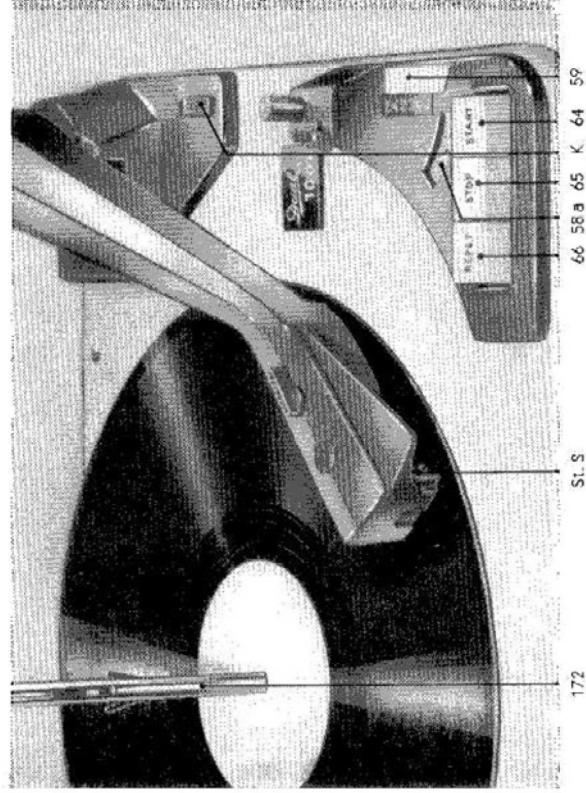

Operating Elements

Automatic Lowering of Arm onto Record

This process will take place in the following sequence:

- a) Arm lifts — Record drops and arm moves towards spindle, then sits down on rotating record on outer pick-up roller.
- b) Because of the angle at which the roller is mounted the arm will be moved by the turning records towards the outer edge of the record until the outer roller has dropped off the surface of the record and the inner roller contacts the record.
- c) The inner roller then moves the arm inward just far enough so that the outer roller touches the edge of the record, thereby indexing the record.
- d) Once more the arm is lifted up and the pick-up rollers recede into the pick-up arm housing.
- e) Finally the arm is lowered and the stylus engages the record grooves.

Tracking pressure of Arm (Stylus tracking pressure)

The built-in scale (58a) permits a check on the tracking pressure of the stylus.

When the arm is placed on the balance, the dial will read the tracking pressure in grams at the stylus point.

This feature is especially helpful because the pick-up heads can be fitted with different cartridges whose weight may not be the same. In order to obtain accurate readings the arm should be tapped lightly.

Adjustment of the tracking pressure is made by the knurled screw located on the front of the arm base. The adjustment of tracking pressure down to a value of $1\frac{1}{2}$ grams will have no effect on operation of the record changer if this value still lies within the capabilities of the particular pick-up cartridge.

3. Adjustments

Arm Position over Rest

Adjust Stop (R 1) after loosening hex nut.

Arm must sit on the base so that the rest is positioned between the two ridges on the underside of the tonearm.

Arm Height Control

Adjust eccentric disc (R 2) at back of pick-up arm base.

Adjustment is correct when the ridges on the underside of the pick-up arm clear the arm rest by .060 inch, as arm moves towards center turntable.

Dropping Position of Arm

Adjust eccentric screw (R 7) of Cam Lever (118).

a) Adjustment is correct, when after the second lowering of the arm, the stylus touches the record .060" ($\frac{1}{16}$ th inch) inward from the rim.

b) An additional means of adjustment for the arm drop position is the set screw (St. S) located on the right side of the cartridge holder. This screw adjusts the position of the outer roller.

Lift of Drawbar (In Arm) for Roll Pick-up

Adjust screw (R 3) on lift arm (121).

a) Adjustment is correct when the lift arm (121) through the first cam, has caused the cap of the release (120) to raise between .008" and .012" above the retaining clip.

b) Additional adjustment of the lift consists of changing the length of the drawbar through screw and eccentric adjustment. However, these are accessible only after removal of the arm from its base.

Brake Adjustment

Use eccentric screw (R 4) on Liftarm (121). Setting is correct when there is a space (gap) of approx. .008" to .012" between the brake peg (122) and clutch (117) while the cam wheel (156) is in zero position.

Lift of Changer Rod

Use eccentric screw (R 6) on dropping lever (158).

for record drop

Adjustment is correct when records drop reliably without any pressure while the changer rod is in its highest position.

Tripping point of Shut-off

Adjust eccentric screw (R 5) on Draw member (115).

The shut-off lever (124) must touch the follower (87 a) when the pick-up stylus, during the play cycle, has reached a record diameter of 5.20 inches.

Rest position of Lift Bar

Adjust eccentric adjustment (R 8) of intermediate lever (46).

Position is correct when, after return of the arm to its rest, the lift rail (47) can move freely past angles (57 and 57 a).

For reference numbers mentioned in this guide, which cannot be found in the illustrations, please refer to the Spare Parts List for Model 1006.

4. Wiring Diagram — Motor Side

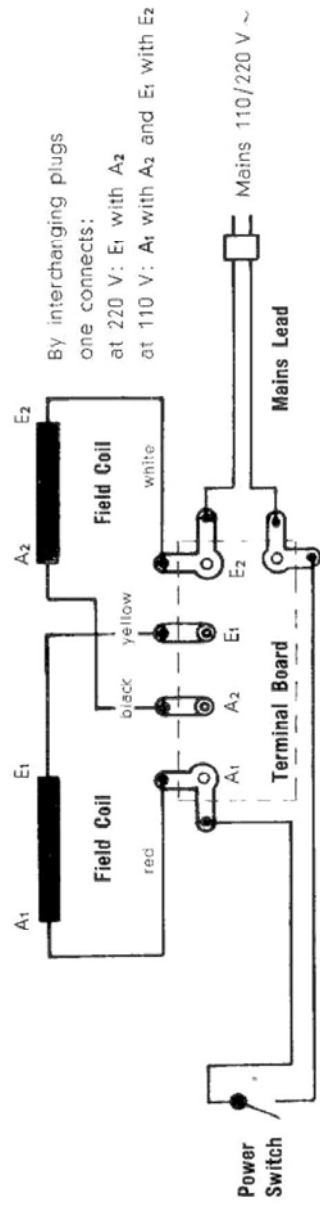

Wiring Diagram — Pick-up Side

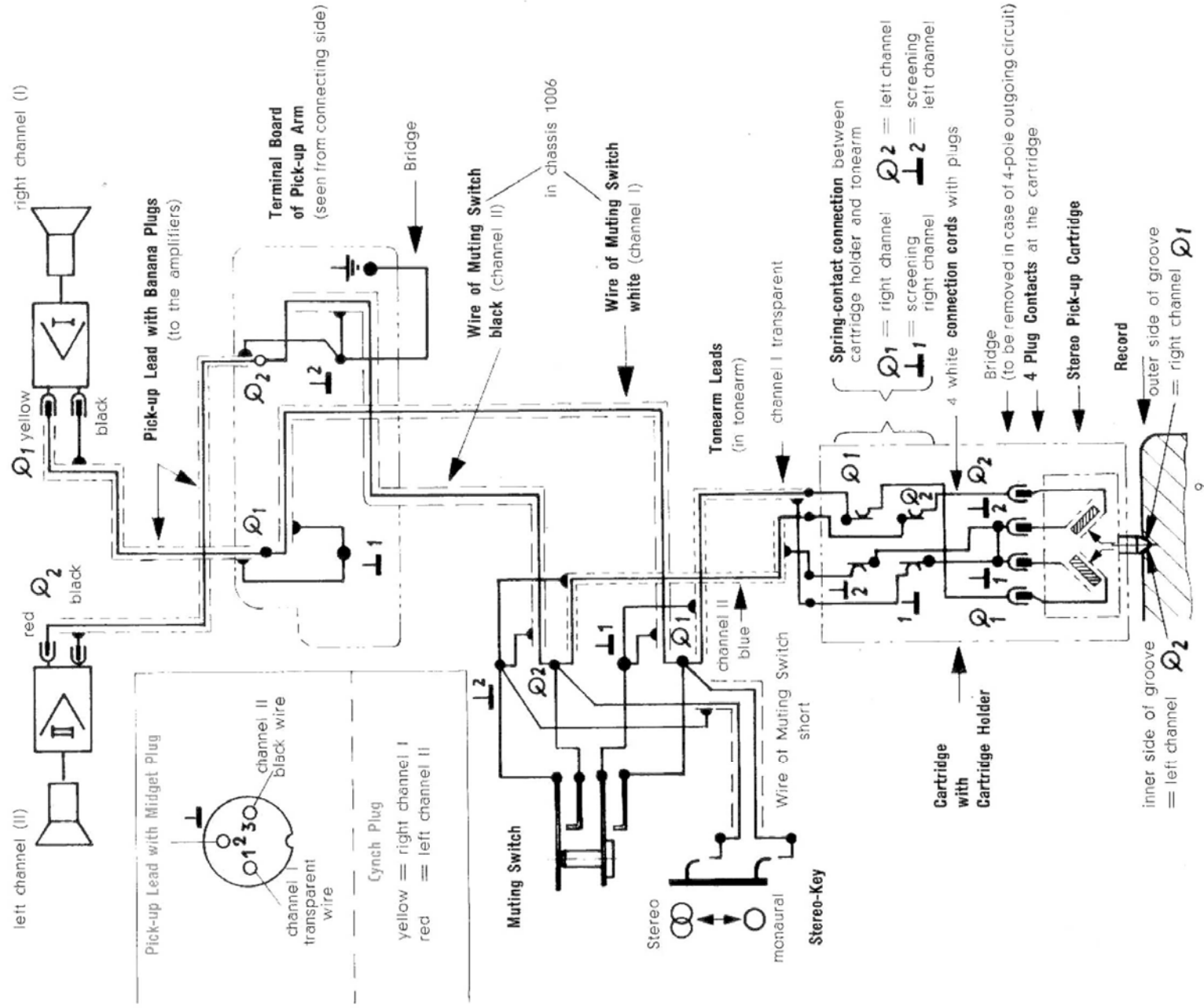

5. Notes

a) Records

Design of the Record Changer is based on the standardized dimensions of phonograph records. The following tolerances are to be noted:

a) Record thickness $.079" \pm .015"$

b) Center holes

12" record	}	.283" + .0035"
10" record		
7" record		

1.50" + .002"

Equally important is the groove pattern. Flawless operation of the changer can be assured when both lead-in and eccentric grooves are located at the proper diameters, and when the stopping groove has the proper pitch. (Inaccurately made records will cause irregular performance of the automatic shut-off for example).

b) Turntable

To further increase the speed accuracy, the following "heavy" turntable is available:

Model 15 / 1006 weighing 3.3 lbs.

c) Pick-up

Aside from the DUAL wide range crystal pick-up Model CDS 420 / 4, Model 1006 Record Changer can be supplied with blank cartridge holders. These will accept all American cartridges having standard mounting dimensions.

d) Changer Spindle

Due to its special construction, no stabilizer arms are required on the Model 1006 Changer. Record drop will be flawless (even with unbalanced weight load), when the center holes of the records are within the above stated limits. It is important that the changer spindle be turned clockwise, after insertion, until a stop is reached.

e) 45 Changer Spindle AS 6

Stacks of records with 1.5" diameter center hole will be dropped accurately. It is recommended to remove the hole reducers which are often supplied with 7-inch records. Faulty drop operation can usually be attributed to worn center holes. (Label left-overs must be removed).

f) Pick-up Cable

If it becomes necessary to increase the length of the pick-up leads (up to 25 feet), only a special replacement cable, available from the authorized distributor should be used. So-called extension cables, available elsewhere are in most instances unsatisfactory.

g) Muting Switch

A 2-channel muting switch is incorporated in the changer. It eliminates noises during the change cycle while the pick-up is lowered and raised. The muting switch opens the pick-up lines only during play or when the unit is at rest.

h) Lubrication

The Changer has been lubricated at the factory. This should be adequate for a long period (up to 2 years, depending on use).

Lubrication, and lubricants shall be in accordance with lubrication chart 1006.

Flawless operation of the changer can only be assured when lubricants recommended by the factory are used.

Important

Turntable should never be removed or replaced unless unit is in zero position !
(Cam-pin with Compression Spring (F 10) engaged in notch of latch segment (162).)



GEBRÜDER STEIDINGER • ST. GEORGEN / BLACK FOREST